



2528-9705

Örgütsel Davranış Araştırmaları Dergisi

Journal Of Organizational Behavior Research

Cilt / Vol.: 7, Sayı / Is.: S, Yıl/Year: 2022, Kod/ID: 22S0-839



## Locating earthing in an imbalanced low-voltage distribution network to reduce imbalances and losses

Javad shahmoradifar

Department of Electrical Engineering (Power), Faculty of Engineering, Islamic Azad University of Ilam, Iran  
Email: Javad.shahmoradi7070@gmail.com

### ABSTRACT

One of the problems of the three-phase four-wire distribution network is the network load imbalance and the high current of the neutral conductor, which causes a drop in the neutral conductor voltage and many problems for the subscribers of these systems. The effect of the imbalance load on the neutral conductor voltage in all busbars in a sample network was investigated in the present paper. It was shown that in an imbalance and asymmetric system, the imbalance load in a busbar can be in the direction of (i) decreasing the voltage of the neutral network and earth equivalent conductor and (ii) increasing the neutral network voltage. Four-wire distribution systems, earthing, fault current, voltage drop, and overvoltage was investigated in the present study. Three-phase four-wire distribution network with multiple protective earthing is widely used in the current distribution network due to more sensitivity protection and fault clearing compared to three-phase three-wire systems. Four-wire systems operate in an imbalance condition due to asymmetric loading. Imbalance is dangerous for the safe operation and safety of a system. In the present study, the possibility of employing an electrical earthing system in the voltage balance of a distribution system and its losses were investigated. The simulation process was performed on a sample distribution system in a MATLAB environment, and the Particle Swarm Optimization (PSO) algorithm was used for locating.

**Keywords:** Distribution network, Decreasing, Balance.

## INTRODUCTION

### 1. Introduction

The earthing (grounding) is an important technical and safety system in the distribution networks. Due to the current conditions and sometimes uneven situation in distribution companies, it is necessary to investigate the earthing system in distribution networks and observe the technical principles of standards to increase the assurance (safety) factor in the proper and safe operation of the networks and prevent the risks of incomplete protection for humans and facilities. The present paper focuses on this topic and introduces electrical earthing systems and protection. Then, the method of using an earth electrode around a grounding distribution station and additional protection measures to prevent dangerous contact voltage in case of a connection to the frame in the devices and machines were investigated. An electrical earthing system means connecting real or virtual neutral points of electrical networks to the earth that is part of an electrical circuit, for example, earthing the transformer winding star center (real neutral point) and earthing the triangle winding transformers through the virtual neutral point neutral bobbin. The importance of the earth point appears when a phase-to-earth connection occurs in the electrical networks. Here, the fault phase current returns to the neutral point of the transformer through the ground and the connection circuit can be cut off by inexpensive-protection devices



such as fuses. If the neutral point is not connected to the earth, the phase-to-earth connection current will be negligible and much lower than the normal phase current due to the lack of return path, and the fuses used for normal current will not cut off the circuit. This leads to a rise in the voltage of the healthy phases relative to the earth, which will cause disturbances in the insulation of the network. In this case, it is necessary to use expensive protection devices to cut off the faulty phase circuit in such a system. To protect a system and ensure safety, each transformer substation must be equipped with a secure electrical earthing and the total resistance of the neutral conductor earthing should not exceed 2 ohms. An earthing system can be used for protection and safety in the following situations: At least one basic earthing system be constructed near each substation, and other earthing systems shall be constructed at the end of the power supply lines with the main boards after the transformer substation. If the medium-voltage input and output lines in a transformer substation are all cable and the length of each line before the substation is not less than 3 km, an earth electrode can be used for both purposes (system protection and ensure safety). The reason is damping step voltage in the cable path equipped with metal armor. However, when there is a possibility of transferring high-voltage (especially lightning) to low-voltage equipment, two earth electrodes are used, and the distance between two electrodes should not be less than 20 m. Hence, a suitable location for installing an earthing system can improve protection in distribution systems. Generally, the networks around each distribution substation are constructed aerially and do not meet the conditions mentioned above. Because the length of medium-voltage cable lines in the substation area does not exceed 3 km, so, it is necessary to separate the earthing system related to medium-voltage equipment from the low-voltage systems. Thus, a low-voltage earthing system is installed separately and at a farther point from each of the distribution low-voltage feeders [1,8]. The protection of distribution systems and appropriate protective equipment for this purpose has been studied in many papers. Important issues of the generation, transmission, distribution, consumption of electrical energy, the earthing system of electrical equipment (and metallic non-electrical), protection against electric shocks, dangerous overvoltages, stabilization of voltage of neutral point in electrical circuits, and their standards and defined methods were investigated in the literature [2], and these investigations and methods were evaluated and tested by simulation for the main problem by connecting a 400 V generator to the 20 kV distribution network of Tafresh University, which finally a suitable earthing system that could provide network safety (when occurring error) was provided. The intrinsic characteristics of the imbalance three-phase four-wire distribution systems were investigated in the literature [3], and the effects of the neutral conductor, earthing system, transient overvoltages, or voltage drop due to a fault in the system were described. The effects of neutral conductor and earthing system on the characteristics of three-phase four-wire distribution systems such as imbalanced voltage, voltage rise or drop due to a fault in the system, and the voltage profile improvement in both permanent and transient states compared to three-phase three-wire distribution systems were examined and evaluated by simulation process, and the desired results were finally obtained. In literature [4], increasing the harmonics in the various standards system was introduced to improve the quality of the electrical power network. In these standards, restrictions are imposed on harmonic injections by nonlinear loads into the network. Due to the problems mentioned above, different methods for removing harmonics were proposed from the beginning. The most basic and common method



for this purpose is to use passive filters. With the development of power semiconductor components manufacturing technology, active filters have been welcomed and used. In these filters, non-linear loads are reduced by proper injection of voltage or current. A new method for controlling the current of the voltage source inverter used in the parallel compensator was presented in the literature [5] to improve the imbalanced loads in the three-phase four-wire system. The proposed method is simple, and in addition to performing the usual tasks of a parallel compensator including power factor correction, reactive power compensation, and attenuation of current harmonics, it enables the parallel compensator to compensate for a significant percentage of the network current imbalance. It also ensures proper stability of the DC junction voltage under extremely imbalanced conditions for a network current or sudden changes in load. Simulations performed in the Simulink environment of Matlab software on the parallel compensator and integrated parallel compensator in different distortion and imbalance conditions for a network voltage and load current showed the ability of the proposed method to improve the network current imbalance. According to the literature [6], one of the most important problems in connecting these sources to the distribution network is the change of short-circuit levels at different points of the network, the disruption in the network protection system, and the malfunction of this system. Installation location, generation rate, type of technology, and network topology will have different effects on the protection system. In this paper, by connecting the DG sources to the IEEE 13-bus test distribution system, the problems caused by this equipment in the protection of the distribution network were investigated in PSCAD/EMTDC software. In the literature [7], the effect of the presence of distributed generation sources on the coordination of protective equipment especially recloser fuses was first investigated, then a new method was proposed to study the effect of the presence of distributed generation sources on the coordination of recloser fuses. Based on the evaluation process of the network protection in different states and the classification of protection coordination status, this method was divided into two categories, including coordination maintenance and loss of coordination. According to the results obtained from this process, the network operator will be able to make the right decision. Then, two complementary solutions were proposed to reduce the number of the non-coordination state. The first solution was to connect the DG to the best busbar (in terms of the number of states in which coordination is maintained), and the second solution was to change the recloser settings. The proposed method was implemented using DlgSILENT and MATLAB software on one of the real electricity distribution networks in Iran. The results showed that the proposed method significantly reduces the number of non-coordination states and prevents interruption of distributed generation sources at the moment of a short-circuit.



### **Modeling earthing system and location objective function with PSO algorithm**

#### **The objective function of the problem**

As mentioned, the purpose of this article is to minimize losses and imbalances in the distribution network. Therefore, we define the following objective function:

$$\text{Min}\{F\} \quad (1)$$

Which, the F function is defined as follows:

$$F = \omega_1 \frac{P_{loss}}{P_{loss0}} + \omega_2 \frac{\sum_{i=1}^n dqv_i}{\sum_{i=1}^n dqv_{o0}} \quad (2)$$

$P_{loss0}$ : Initial losses

$P_{loss}$ : Losses considering the earthing system

$\omega_1, \omega_2$  : Weighting coefficients of the objective function, which :  $\omega_2 + \omega_1$

$dqv_i$ : The voltage balance index in the initial state.

$dqv_o$ : The voltage balance index considering the earthing system which is defined for each bus as follows:

$$dqv = \sqrt{\frac{1 - \sqrt{3 - 6\beta}}{1 + \sqrt{3 - 6\beta}}} \quad (3)$$

Which, the coefficient is defined as follows:

$$\beta = \frac{|V_{ab}|^4 + |V_{bc}|^4 + |V_{ca}|^4}{[|V_{ab}|^2 + |V_{bc}|^2 + |V_{ca}|^2]^2} \quad (4)$$

This problem is considered as Fig. 1

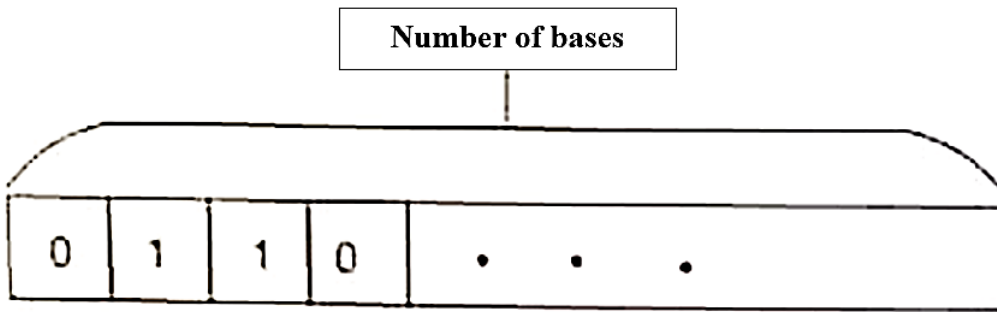

Fig. 1. Structure of a proposed particle

A particle is an array with a length equal to the number of bases, of which “0” means that there is no earthing system, and “1” means choosing the base as the installation location of the earthing system.

#### Particle distribution in the unbalanced four-wire network

A characteristic of a low-voltage distribution network is that it is imbalanced, and this imbalance passes through the neutral conductor. Thus, an algorithm that can consider this imbalance is needed for load distribution. The Backward Sweep (BS) method was used in the present study for load distribution, which was implemented in three steps and according to a single-line diagram (as shown in Fig. 2).

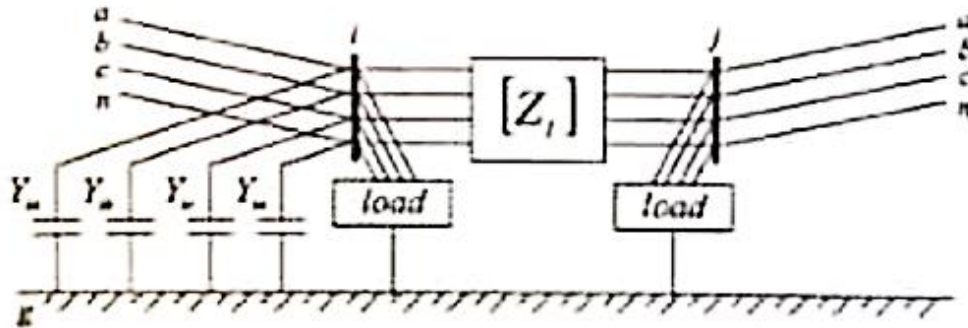

Fig. 2. A section of the low-voltage four-wire network

In the load distribution algorithm, the three phases of each node or part of the line are defined by a single index, regardless of the number of phases of these nodes or lines. Fig. 4 shows distribution L between nodes i and j with shunt impedance,  $Z_L$ , and nodes load.

$$Z_L = \begin{bmatrix} Z_{aa} & Z_{ab} & Z_{ac} & Z_{an} & Z_{ag} \\ Z_{ab} & Z_{bb} & Z_{cb} & Z_{nb} & Z_{bg} \\ Z_{ca} & Z_{cb} & Z_{cc} & Z_{cn} & Z_{cg} \\ Z_{an} & Z_{nb} & Z_{nc} & Z_{nn} & Z_{ng} \\ Z_{ag} & Z_{gb} & Z_{gc} & Z_{gn} & Z_{gg} \end{bmatrix} \quad (5)$$

Where,

a,b,c: Phase lines

n: Neutral conductor

g: Earth

If each of the phases, neutral conductor, or related earth does not exist, the corresponding rows and columns in the matrix will be all "0". The capacity of the shunt LV can be omitted.



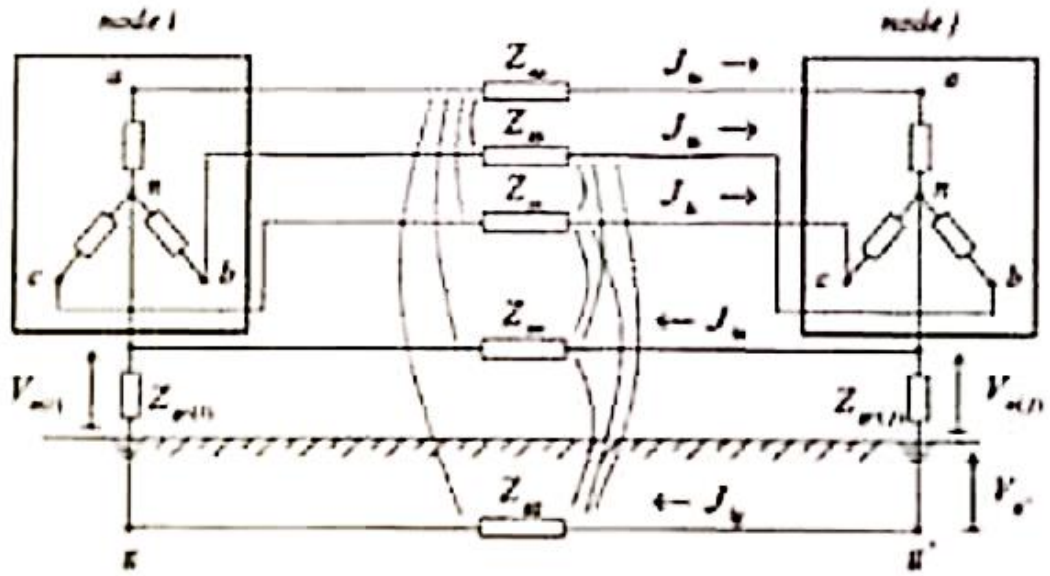

Fig. 3. Four-wire network model



Step 1: Calculation of the currents

$$\begin{bmatrix} J_{ia} \\ J_{ib} \\ J_{ic} \\ J_{in} \\ J_{ig} \end{bmatrix}^{(K)} = \begin{bmatrix} \left(\frac{S_{ia}}{V_{ia}}\right)^{(k-1)*} \\ \left(\frac{S_{ib}}{V_{ib}}\right)^{(k-1)*} \\ \left(\frac{S_{ic}}{V_{ic}}\right)^{(k-1)*} \\ \frac{Z_{ig}}{Z_{nin}+Z_{ig}} (S_{ia}^{(k)} + I_{ib}^{(k)} + I_{ic}^{(k)}) \\ \frac{Z_{nin}}{Z_{nni}+Z_{gi}} (S_{ia}^{(k)} + I_{ib}^{(k)} + I_{ic}^{(k)}) \end{bmatrix} \begin{bmatrix} Y_{ia} & & & & \\ & Y_{ib} & & & \\ & & Y_{ic} & & \\ & & & Y_{in} & \\ & & & & 0 \end{bmatrix} \begin{bmatrix} V_{ia} \\ V_{ib} \\ V_{ic} \\ V_{in} \\ V_{ig} \end{bmatrix}^{(K-1)} \quad (6)$$

Where,

$I_{ia}, I_{ib}, I_{ic}$ : The Injected currents to the  $i^{\text{th}}$  busbar

$S_{ia}, S_{ib}, S_{ic}$ : The apparent power of electricity subscribers in the  $i^{\text{th}}$  busbar

$V_{ic}, V_{in}, V_{ib}, V_{ia}$ : The voltages of  $i^{\text{th}}$  busbar

$Y_{ic}, Y_{in}, Y_{ib}, Y_{ia}$ : Admittance of shunt elements of  $i^{\text{th}}$  busbar

$Z_{gri}$ : Earth impedance in  $i$ -th busbar, which  $Z_{gi} = Z_{gri} + Z_{ggi}$



### Step 2: Calculation of the lines current

At this step, as known, the process starts from the last layer (or bottom line) and goes back, and the current of each line is equal to the sum of the currents of the lines that are in front of it.

$$\begin{bmatrix} J_{ia} \\ J_{ib} \\ J_{ic} \\ J_{in} \\ J_{ig} \end{bmatrix}^{(K)} = - \begin{bmatrix} I_{ia} \\ I_{ib} \\ I_{ic} \\ I_{in} \\ I_{ig} \end{bmatrix}^{(K)} + \sum_{m \neq M} \begin{bmatrix} J_{ma} \\ J_{mb} \\ J_{mc} \\ J_{mn} \\ J_{mg} \end{bmatrix} \quad (7)$$

$J_{ib}, J_{ia}, J_{in}$ : Current in the  $i^{\text{th}}$  line

$M$ : The number of lines in front of the  $J$ -th busbar

### Step 3: Calculation of the busbars voltage

$$\begin{bmatrix} V_a \\ V_b \\ V_c \\ V_n \\ V_g \end{bmatrix}^{(K)} = \begin{bmatrix} V_a \\ V_b \\ V_c \\ V_n \\ V_g \end{bmatrix}^{(K)} - \begin{bmatrix} Z_{aa} & Z_{ab} & Z_{ac} & Z_{an} & Z_{ag} \\ Z_{ab} & Z_{bb} & Z_{cb} & Z_{nb} & Z_{bg} \\ Z_{ca} & Z_{cb} & Z_{cc} & Z_{cn} & Z_{cg} \\ Z_{an} & Z_{nb} & Z_{nc} & Z_{nn} & Z_{ng} \\ Z_{ag} & Z_{gb} & Z_{gc} & Z_{gn} & Z_{gg} \end{bmatrix} \begin{bmatrix} J_{ia} \\ J_{ib} \\ J_{ic} \\ J_{in} \\ J_{ig} \end{bmatrix} \cdot (K) \quad (8)$$

Where,

$Z_{aa}$ ,  $Z_{bb}$ ,  $Z_{cc}$ , and  $Z_{nn}$ : The lines impedance of the phases and the neutral conductor.

### Voltage correction

Voltage correction should be done in busbars with earthed neutral and downstream busbars. Voltage in busbars with earthed neutral for  $k^{\text{th}}$  repetition is defined as follows:

$$V_{in}^k = Z_{gn} j_{ig}^{(k)}, i \in \{Grounded\ nodes\} \quad (9)$$

The above steps continue until the error value specified for the power is less than a value defined by us.

### Optimization using Particle Swarm Optimization (PSO) algorithm

#### History of the PSO algorithm:

Particles swarm optimization by birds algorithm is an optimization technique based on collective intelligence and acts according to the initial answers. This technique was first developed by Eberhart and Kennedy in 1995 based on the social behavior of flocks of birds and fishes.

#### Optimization using the PSO algorithm

In many cases, this technique acts similar to evolutionary computational techniques like Genetic Algorithms (GA). In this algorithm, the system starts to run with some initial answers and tries to find the optimal answer by moving or dislocating these answers during successive repetitions. Unlike genetic algorithms, the PSO algorithms do not include evolutionary operators such as mutations or crossover (recombination). The problem answers in the PSO (particles) are the search space to find the optimal results for a system. The PSO algorithm acts based on the social behavior of a flock of birds. To better understand this technique, the following scenario is considered: "A flock of birds randomly search for food in a certain area. There is only one piece of food in this area, while the birds do not know the location of the food, but they know their distance from the food location at each moment." In this condition, a proper strategy to find the exact location of the food is to follow the bird that is closer to the food than other birds. The PSO algorithm is inspired by such a scenario and offers a solution for the optimization of the problems. In the PSO algorithms, each bird acts as a solution to a problem. All available answers have a competency value that is obtained from the function defined for the problem. The fundamental of this technique is to find the location with the best competency in the problem

space. This value has a direct impact on the speed of movement of these birds from problem answers to the location (optimal answer).

### Introducing the PSO method

The basis of this method is to find the optimal solution using the particle swarm. Each particle is a candidate and represents a solution to the problem. Some of the interesting features of the PSO method are (i) simplicity, and (ii) high speed compared to other evolutionary methods such as a genetic algorithm. In the PSO algorithm, there is a swarm of “m” particles, in which each particle “i” with a mass of  $m_i$  has a location of  $X_i(t)$  and speed of  $V_i(t)$  in a D-dimensions search space.

$$Pop(t) = (x_1(t), x_2(t), \dots, x_n(t)) \quad (10)$$

$$V_i = (v_{i1}, v_{i2}, \dots, v_{iN}) \quad (11)$$

$$X_i = (x_{i1}, x_{i2}, \dots, x_{iN}) \quad (12)$$

$$Pbest_i = [Pbest_{i1}, \dots, Pbest_{iN}] \quad (13)$$

$$Gbest_i = [Gbest_{g1}, \dots, Gbest_{gN}] \quad (14)$$

$$V_i^{l+1} = W \cdot V_i^l + C_1 \cdot Rand(0.1) \cdot (Pbest_i - X_i^l) + C_2 \cdot Rand(0.1) \cdot (Pbest_g - X_i^l) \quad (15)$$

$$V_i^{l+1} = X_i^l + V_i^{l+1} \quad (16)$$

**(a) Particle swarm (pop (t)):** “m” particles that are initially randomly located and lead the function to the optimal answer.

**(b) P<sub>best</sub>:** This parameter indicates the best location that each particle has gained during the algorithm execution.

**(c) G<sub>best</sub>:** This variable indicates the best location that all the particles have gained during the algorithm execution.

**(d) Personal recognition (C<sub>1</sub>):** This coefficient causes the particle to move due to Pser to the best location which it has ever gained.

**(e) Global recognition parameter (C<sub>2</sub>):** This coefficient causes the particle to move towards GBest, the best location that all the particles have ever gained.

**(f) Inertia coefficient/mass coefficient (W):** This coefficient leads to the balance in local and global searching in the algorithm.

**(g) Speed (V):** This parameter shows the change in location of the particle in the search space. The path of the particle movement is shown in Fig. 3. As can be seen in Fig.3, the location of the particle at the next moment is determined using the two parameters “Pies” and “Guest”. The third effective factor in the determination of the future location of the particle is the previous speed of the particle. These three factors together determine the future location of the particle. In other words:

$$V_i^{l+1} = X_i^l + V_i^{l+1} \quad (16)$$



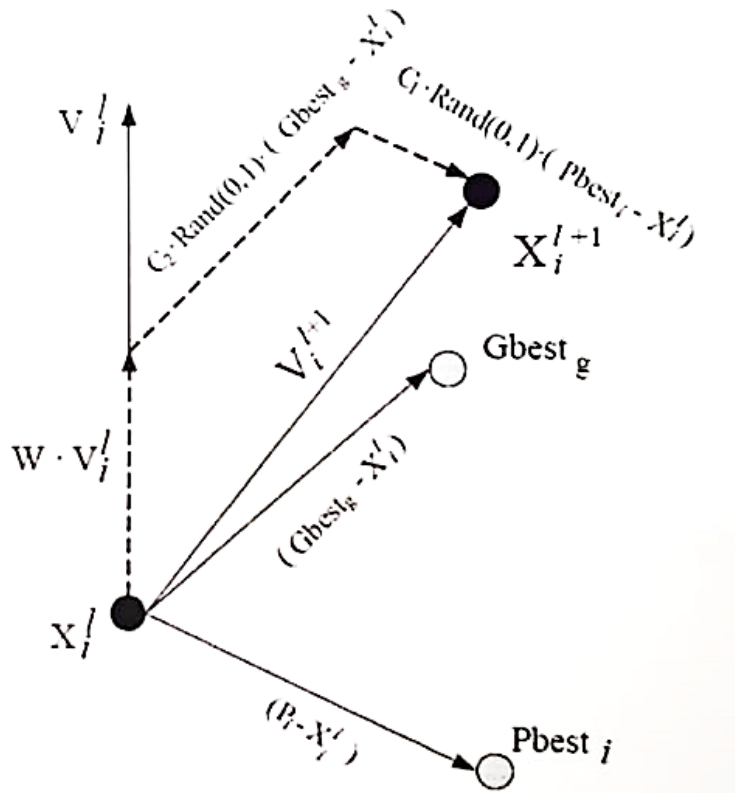

Fig. 4. Mechanism of the PSO algorithm

Hence, if  $C_2 \gg C_1$ , the particles tend to  $G_{best}$  (global-best positions). Whereas, if  $C_1 \gg C_2$ , particles tend to  $P_{best}$  (personal-best positions). In this case, to have an average state, it must be  $C_1 = C_2$ . In this case, the tendency to reach  $P_{best}$  and  $G_{best}$  will be equal. If  $C_1$  and  $C_2$  are large values, the speed of reaching the optimal points will increase, whereas the accuracy of calculating the optimal point will decrease and the probability of fluctuation in the calculation of optimal points in this algorithm will increase. On the other hand, if the values of  $C_1$  and  $C_2$  are small, the accuracy of calculating the optimal point will increase, whereas the speed of reaching optimal points will decrease. In general, the condition  $C_1 + C_2 \geq 4$  is established for  $C_1$  and  $C_2$ . Normally,  $C_1 = C_2 = 2/05$  is considered to meet these two conditions (speed and accuracy). The inertia coefficient or mass “W” leads to reaching the optimal point. The small values of W cause slow movement (displacement) of points, and so, the search space becomes small. On the other hand, the large values of W, result in a large range of movements, and so, search space becomes large. If  $W = 0$ , the particle swarm reaches the endpoint with a highly accurate. If  $W = 1$ , the particle swarm reaches the endpoint, slowly. Thus, when running the algorithm, small values of W lead to rapid convergence in an optimal local location while large values of W prevent convergence. Normally, in the running the PSO algorithm, the value of W must be adjusted during the training and reduced linearly from 1 to near 0. The following equation is used to set W.

$$\omega = \omega_{max} - \frac{\omega_{max} - \omega_{min}}{Iter_{max}} \times Iter \quad (17)$$

$Iter_{max}$  : The maximum number of repetitions

$Iter$  : The current repetition number

$\omega_{max}$  : The maximum value of the inertia coefficient

$\omega_{min}$  : The minimum value of the inertia coefficient

### The problem of optimal planning and formulation for home appliances

In this section, the planning of appliances performance is formulated and presented using linear planning mixed with integers and binary variables. The proposed solution is represented below.

#### Problem specifications

For planning, a set of appliances is specified with a number of “N” and their specifications are determined based on “i” (from 1 to N). The amount of power of the appliances is different and its amount is specified in section “k”.

#### Determinant variables

The unit of  $P_{ij}^k$  is kWh. By multiplying it by a factor (15/60=0.25), it can be represented in a unit of kW.  $P_{ij}^k$  is the actual (or active) value of the load. In addition to  $P_{ij}^k$ , an auxiliary binary variable is needed to determine the load processing. The binary determinant variables are shown as  $X_k^{ij} \in \{0,1\} X_k^{ij} = 1$ . For example, appliance “i” with a phase of load “j” is processed at the time of part “k”, otherwise  $X_k^{ij} = 0$ . Similarly, we can show other binary auxiliary variables with  $S_k^{ij} = 0$  that the processing for appliance “i” with a phase of load “j” is performed at time “k”. This shows that  $X_k^{ij}$  and  $S_k^{ij}$  are complementary, and the binary variables are  $X_k^{ij} = 1$  and  $S_k^{ij} = 1$ , for example:

$$X_k^{ij} + S_k^{ij} = 1 \quad \forall i, j, k$$



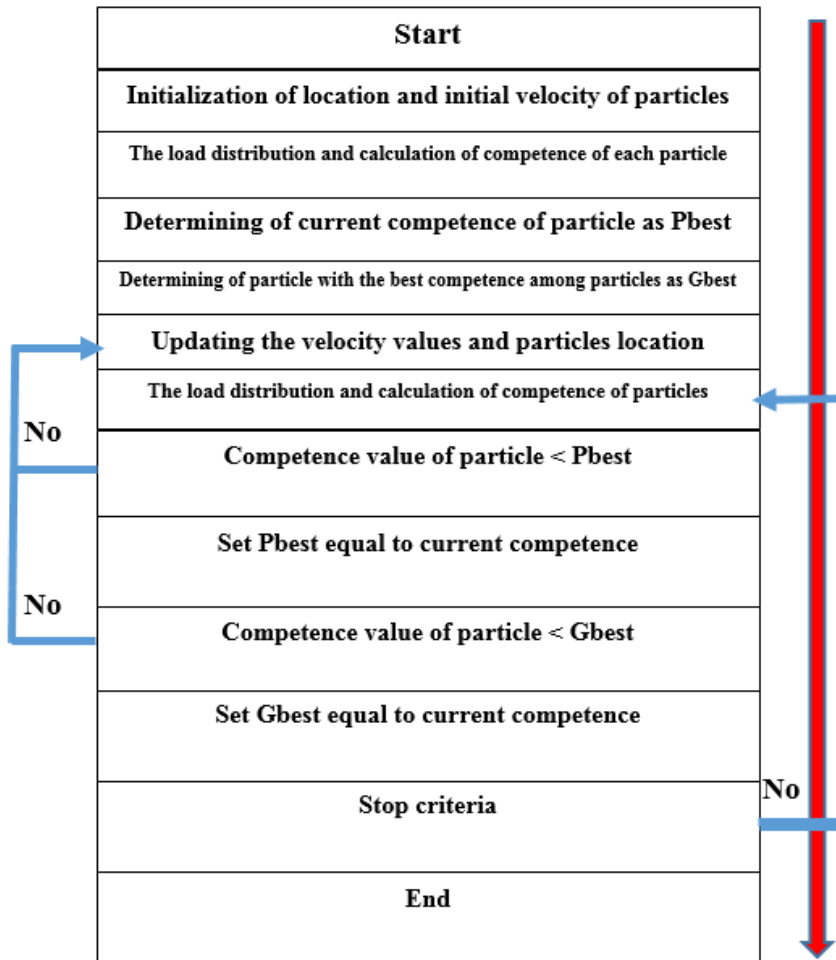

Fig. 5. The proposed flowchart for the PSO algorithm

## Results

The test network used in the present investigation was a low-voltage network located in Mosian city (south of Ilam province). This city has 26 bases and its single-line diagram is shown in Fig. 6. Table 1 shows the values of the PSO parameters. Before running the algorithm, the load balancing was performed in the test network, and the loads were divided equally between the different phases. The optimization results are listed in Table 2. According to Table 2, bases of 4, 9, 13, 17, 30, and 42 were diagnosed to be suitable for installing the earthing system. Finally, it was founded that the loss rate has been reduced from 2579 W to 1922 W.

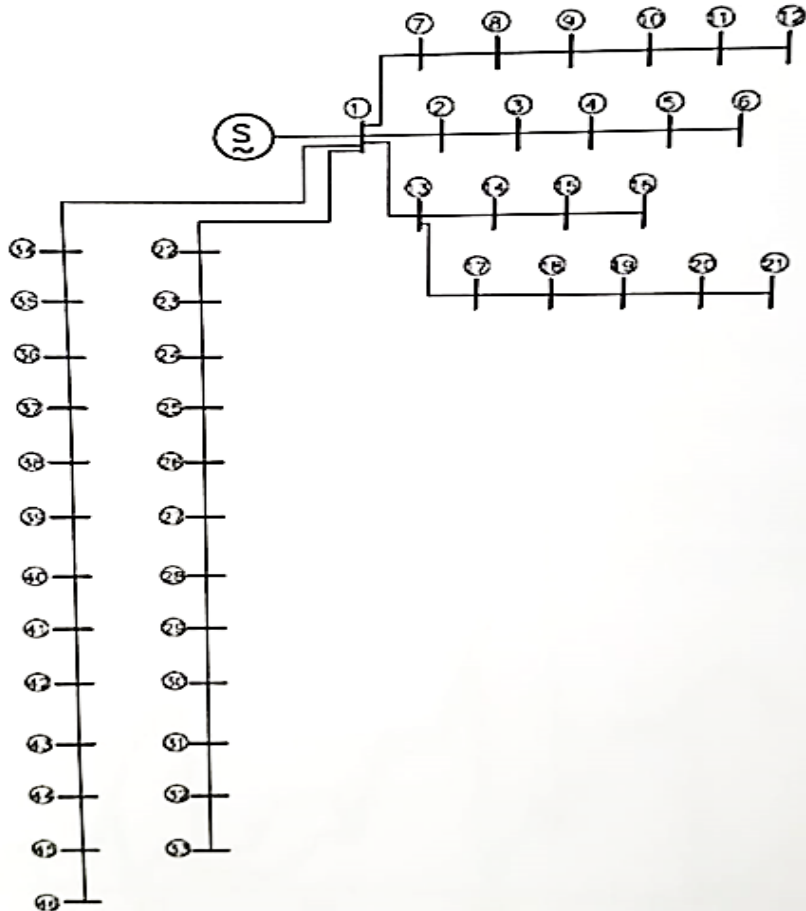

Fig. 6. Network

Table 1. Parameters of the PSO setting

Parameter	Value
Number of sub-swarm	46
Number of particles	0
Maximum coefficient value	0.9
Minimum coefficient value	0.2
$C_2$ & $C_1$	2
The number of repetitions	50
Every initial speed of every generation	30

Table 2. Results of optimal selection of earthing system location

Voltage balance index	Losses	Location of bases
0.119	1922	4,9,13,17,30,42



The voltage diagram of the neutral conductor at the foundations (bases), before/after installing the earthing system is shown in Fig. 7. As shown, the neutral voltage has decreased after installing the earthing system.

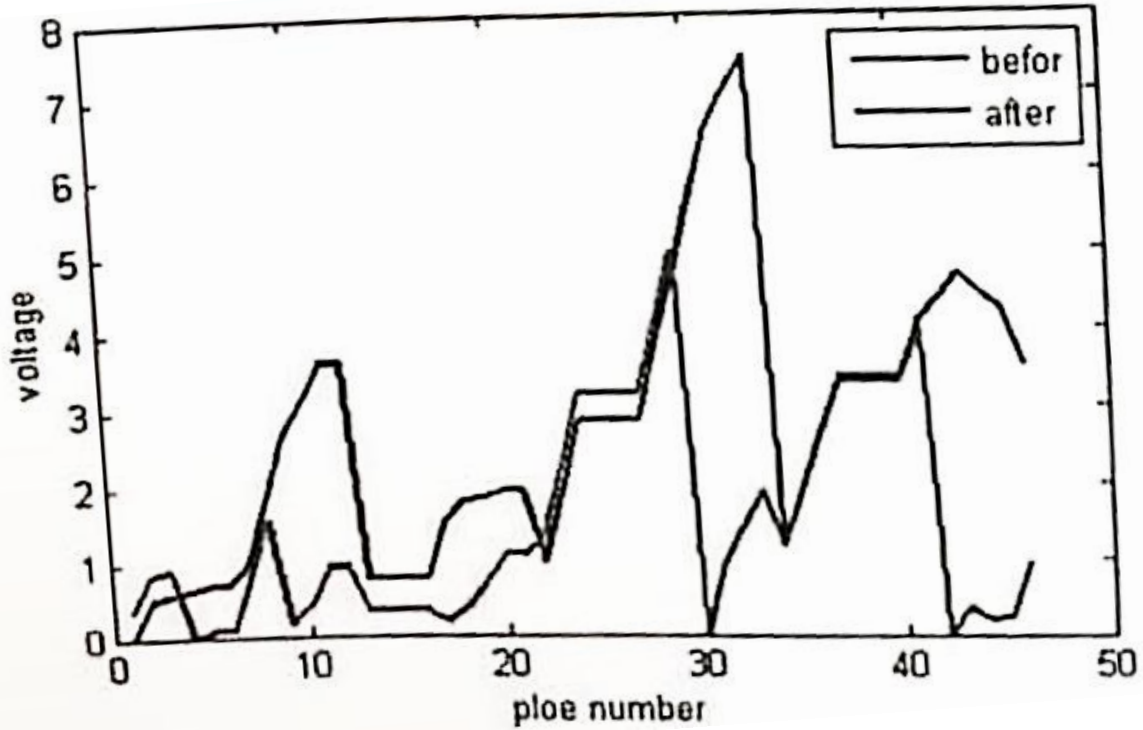

Fig. 7. The neutral voltage before/after installation of the earthing system

The imbalance index for the foundations (bases) before and after the installation of the earthing system is shown in Fig. 8. According to Fig. 8, the amount of imbalance has decreased after the installation of the earthing system. The total imbalance index before the installation of the earthing system was equal to 0.1235, which decreased to 0.119 after the installation of the earthing system.

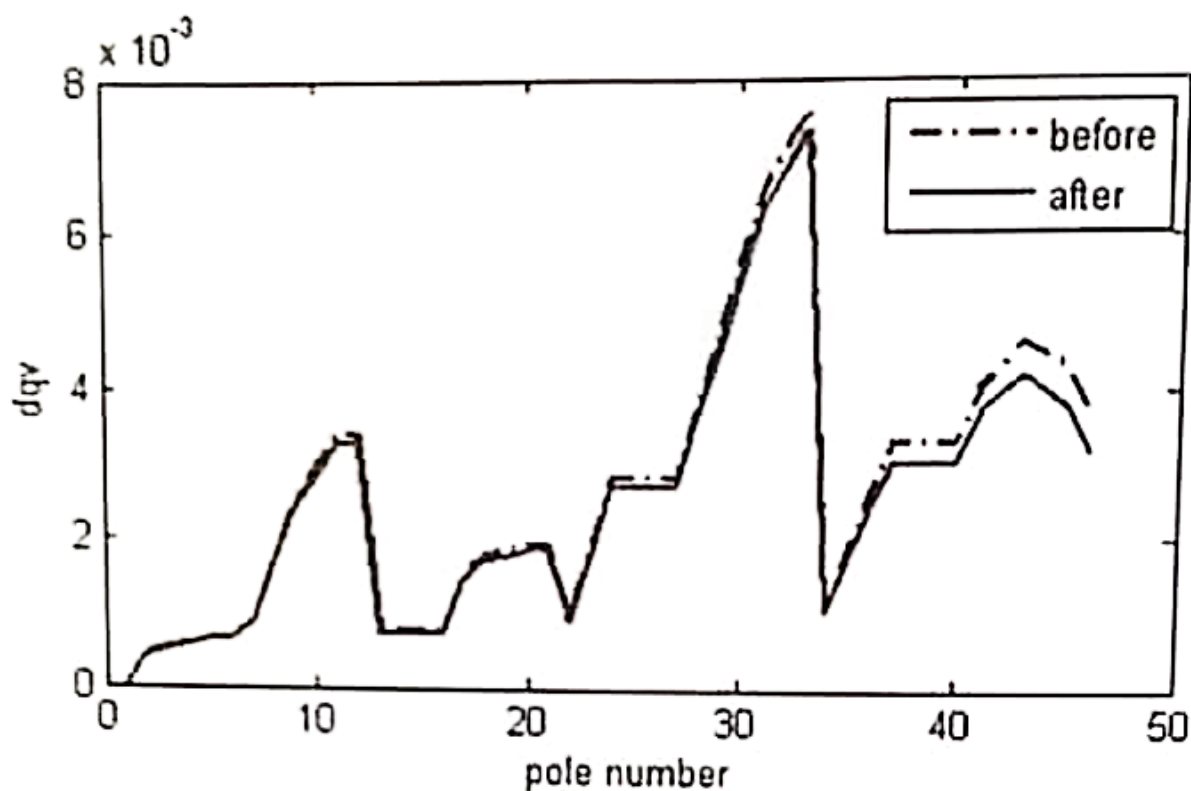

Fig. 8. Voltage imbalance index before/after installation of the earthing system



### Conclusions

Since reducing losses and balancing network voltage is one of the main aims of electric power distribution companies, so locating an electrical earthing system for this purpose can lead to useful results. Hence, it is suggested that by practical implementation of results of simulation and calculations of losses and voltage balance in similar networks, this method can provide high-quality and reliable electricity to all subscribers.

**Acknowledgment:** NONE

**Conflict of Interest:** NONE

**Funding:** NONE

**Ethical statements:** NONE

### References

1. Seyed Massoud Mortezaeinejad, Iran, Tehran, University of Science and Technology, Tehran, Saadat Abad, Telecommunication Town, Shahid Sobhi St., Alborz Tower, Unit 50, Ahmad Gholami.
2. Ahmad Gholami, Iran, Tehran, Resalat Square, Hengam St., University St., University of Science and Technology, Volume 2, pp. 12-23.

3. Ali Asghar Pak Nemat Province, Farzad Razavi, University of the Ministry of Science, Research and Technology, Tafresh University, Faculty of Electrical Engineering, 2010.

4. Hassan Parroui Suraki, University of the Ministry of Science, Research and Technology, University of Kurdistan, 2009.

5. Majid Pakdel, University, Ministry of Science, Research and Technology, Isfahan University of Technology, Faculty of Electrical and Computer Science.

6. Saeed Yeganehfar, Ministry of Science, Research and Technology, Birjand University, Faculty of Electrical and Computer Engineering, 2014.

7. Ebrahim Babaei Hirsh Sidi, Ministry of Science, Research and Technology, University of Tabriz Credit Judge, 2011.

8. Ahmad Amini Moghadam, Morteza Razaz, Seyed Ghodratollah Seif Sadat Mohsen Saniei, Ministry of Science, Research and Technology, Shahid Chamran University of Ahvaz, Faculty of Engineering, 2013.

