



## A STUDY ON FACTORS AFFECTING THE APPLICATION OF SOCIAL RESPONSIBILITY ACCOUNTING IN MANUFACTURING ENTERPRISES OF VIETNAM

Pham Thi Bich THU<sup>1\*</sup>

<sup>1</sup>Faculty of Economics and Business Administration, Hong Duc University, Thanh Hóa Province, Vietnam.

**\*Corresponding Author**

**E-mail:** phambichthu@hdu.edu.vn

### ABSTRACT

The main aim of this research is to assess and analyze the various factors that affect the integration of social responsibility accounting (SRA) in manufacturing companies operating in Vietnam. Moreover, this study is about investigating the relationship between the application of social responsibility accounting and overall business performance. To achieve these objectives, an extensive survey involving 231 managers at all levels from different hierarchical levels was conducted. The data collected was then analyzed using a structural equation model (SEM) to examine the proposed relationships within the theoretical framework. The research findings indicate that several factors, including the competency and awareness levels of managers and accounting personnel, corporate strategy, information technology (IT) applications, and legal regulations, all have a significant impact on promoting the adoption of social responsibility accounting. Furthermore, the study provides further evidence to support the positive influence of implementing social responsibility accounting on operational performance, thus reinforcing its practical benefits.

**Keywords:** Social responsibility accounting (SRA), Operational performance, Vietnam, Structural equation model (SEM).

### INTRODUCTION

Recently, social responsibility has garnered significant attention in both academic literature and the business community. This heightened focus is attributed to the growing recognition among businesses that their role extends beyond profit maximization to encompass broader social responsibilities (Su & Jie, 2015; Su *et al.*, 2022). Social responsibility entails engaging in specific activities by firms that align their economic, environmental, and social objectives within their strategic frameworks and operational choices.

Social responsibility is gradually becoming a trend in economic development, bringing many tangible benefits to companies such as cost reduction, increased revenue, enhanced brand value, decreased employee turnover, increased productivity, and access to new markets. Implementing CSR not only helps companies preserve and develop their corporate culture, elevate brand value and reputation, protect the rights, and create favorable working conditions for employees, but also helps attract talented individuals and a high-quality workforce, achieve economic circularity, minimize costs, and effectively manage towards sustainable development.

In the past, social responsibility accounting was not given much emphasis. However, with the trend of globalization, companies have realized that promoting CSR has a positive correlation

Geliş tarihi/Received: 03.12.2022 – Kabul tarihi/Accepted: 14.03.2023 – Yayın tarihi/Published: 30.03.2023

© 2023 Journal of Organizational Behavior Research. **Open Access** - This article is under the CC BY license (<https://creativecommons.org/licenses/by/4.0/>)



with the reputation and effectiveness of the business. Along to maximize profits for the company, social responsibility accounting becomes more meaningful to society by providing reports that reflect information about the company's strategies and values, while also demonstrating the company's commitment to CSR for stakeholders. Khan *et al.* (2022) suggest that social responsibility reporting is an increasingly important aspect of virtual business transparency. Managers have a distinctive chance to highlight their company's initiatives and contributions to economic and social progress through social responsibility disclosure, as the decisions and attitudes of decision-makers directly influence social responsibility reporting.

In the context of Vietnam, the initial reference to information concerning the reporting of social responsibility can be traced back to Circular No. 155/2015/TT-BTC, issued on October 6, 2015, by the Ministry of Finance. This circular guides the disclosure of information related to social responsibility on the stock market. Currently, Circular No. 96/2020/TT-BTC, which amends certain provisions of Circular 155, is the sole legal document governing the disclosure of information on social responsibility for enterprises listed on the stock market in Vietnam. Notably, there are no specific regulations in place regarding the application of social responsibility accounting. As a result, the organizing and implementation of social responsibility accounting in Vietnamese manufacturing enterprises remain relatively indistinct and rudimentary. Therefore, the study aims to construct a research model that examines the factors influencing the adoption of social responsibility accounting and to test the relationship between the application of social responsibility accounting and the operational performance of the enterprises.

### *Literature Review*

#### *Social Responsibility Accounting*

Social responsibility accounting has evolved in response to the incessant demands of society, as well as the economic, political, and social conditions of each nation, the world, and the perspectives of relevant researchers and international organizations. Social responsibility accounting is derived from two fundamental elements: accountability and sustainability (Gray *et al.*, 2014). Accountability entails providing information to stakeholders about a company's activities related to CSR. Sustainability involves the balanced utilization of resources to ensure their preservation for the future.

Social responsibility accounting refers to the voluntary obligations undertaken by a company (Van Marrewijk & Werre, 2003). According to Gray *et al.* (1988), social responsibility accounting evaluates the societal impact of a firm's economic activities and addresses the socio-environmental concerns of its stakeholders. Al-Qudah (2023) defines social responsibility accounting as a branch of accounting that provides information enabling the assessment of the societal impact of an economic entity's activities. It involves measuring the social performance of organizations to aid users of financial statements in making economic decisions and evaluating the social performance of these organizations.

Social responsibility accounting is a discipline that encompasses the systematic observation, measurement, calculation, recording, reflection, processing, and analysis of information pertaining to the CSR endeavors undertaken by enterprises. These include activities related to environmental protection, contributions to the social community, obligations towards suppliers,



responsibilities towards employees, and ensuring the welfare and safety of consumers. The application of social responsibility accounting extends to the business operations and interactions of enterprises, correlating with the outcomes and effectiveness of their production and commercial activities. As a result, social responsibility accounting furnishes valuable information for managers, governmental bodies, environmental management agencies, and other pertinent stakeholders.

### *Factors Influencing the Application of Social Responsibility Accounting Corporate Strategies*

Corporate strategies play a pivotal role in addressing corporate social responsibility and integrating SRA within organizations. Stakeholders exert pressure on companies to adopt CSR practices by demanding that they enhance strategic planning in this regard (Galbreath & Benjamin, 2010). Developing a comprehensive strategy that aligns with the company's development orientation, perspective, and operational philosophy is crucial for effectively implementing corporate social responsibility. This strategy enables businesses to consistently plan and work towards achieving their objectives (Galbreath & Benjamin, 2010; Kalyar *et al.*, 2013). Consequently, if CSR is included as one of the enterprise's strategies, SRA will likely be implemented. Based on this premise, the following hypothesis is proposed by the author:

*Hypothesis 1: Corporate Strategy Has a Positive Influence on the Application of Social Responsibility Accounting.*

### *Awareness and Commitment of Senior Managers to Social Responsibility Accounting*

Managers assume a crucial role in formulating strategic, implementing, and overseeing the execution of CSR initiatives, alongside responsibility accounting within enterprises. Empirical evidence underscores that the effectiveness of social responsibility accounting hinges upon the genuine awareness of business managers regarding the paramount importance of CSR for organizational prosperity, coupled with the support they receive from managerial counterparts. Shixian (2014) corroborates this viewpoint, affirming that the adoption of corporate accounting practices within enterprises is contingent upon the training proficiency and managerial competence exhibited by business leaders. Remarkably, a higher level of management engenders augmented management efficiency and heightened acumen in applying CSR principles.

*Hypothesis 2: The Level of Qualifications and Awareness among Managers Exerts a Positive Influence on the Implementation of Social Responsibility Accounting within Enterprises.*

### *Accounting Personnel*

Al-Htaybat and Alberti-Alhtaybat (2013) underscore the noteworthy influence of education and skill proficiency among accounting staff and managers on the accounting process. Likewise, Nawaiseh *et al.* (2014) accentuate that the absence of training programs for accountants constitutes one of the impediments to the successful implementation of social responsibility accounting. Correspondingly, the research conducted by Ern *et al.* (2016) reveals that competent accountants exert a positive impact on the adoption of management accounting systems, with particular emphasis on social responsibility accounting practices.



*Hypothesis 3: The Capacity of Accounting Personnel Has a Positive Influence on the Application of Social Responsibility Accounting.*

The cost associated with implementing social responsibility accounting cost is a crucial consideration that significantly influences various decisions within a business. Several studies have indicated that, although businesses may acknowledge the significance of implementing social responsibility accounting and allocate resources for facilities and staff, the substantial cost involved in designing and operating the social responsibility accounting system can pose a significant barrier to its adoption. This cost factor represents a substantial obstacle to the application of social responsibility accounting. Based on the above analysis, hypothesis 4 is built as follows:

*Hypothesis 4: The Cost of Organizing Private Accounting Has a Negative Effect on the Application of Social Responsibility Accounting.**IT Application*

Raewf and Jasim (2020) draw the conclusion that the utilization of information technology brings about substantial transformations in the field of accounting. Susanto and Meiryani (2019) highlight the importance of upholding the quality of information technology through the establishment of advanced infrastructure and the cultivation of a highly proficient workforce, enabling the accurate representation of IT expertise in environmental accounting. Based on this, the author formulates hypothesis 5 as follows:

*Hypothesis 5: The Use of Information Technology Positively Affects the Implementation of Social Responsibility Accounting.**Legal Regulation Pressure*

The activities of an organization are not only aimed at achieving effective goals, but they are also subject to the influence of constitutional, legal, and other factors such as political, economic, social, and cultural norms. These external influences exert pressure on the behavior, organizational structure, and operational processes of the enterprise, necessitating adjustments to align with and meet the established standards. This alignment serves as a basis for enhancing the enterprise's capacity to develop and operate within the legal framework, in compliance with regulations, and relation to relevant stakeholders. Therefore, every enterprise engaged in production and business operations is subject to institutional pressures and must adhere to the provisions of the law, ensuring that its activities are regulated and conducted within the boundaries defined by legal regulations.

*Hypothesis 6: The Legal Environment Has a Positive Influence on the Application of Social Responsibility Accounting.**Operational Performance*

Performance measures may be characterized as financial and non-financial. Operational performance pertains to quantifiable aspects of an organization's processes, such as reliability, production cycle time, and inventory turnover. The effectiveness of operational performance, in



turn, impacts business performance indicators like market share and customer satisfaction (Voss *et al.*, 1997). Tran *et al.* (2022), performance is one important aspect of management accounting in general, and, more specifically, responsibility accounting. Social responsibility accounting was confirmed to have a positive effect on the performance of profit center managers; proper responsibility accounting will support excellent manager performance (Tuan, 2017).

*Hypothesis 7: The Application of Social Responsibility Accounting Has Affected Positively the Firms' Operational Performance.*

From the above-mentioned hypotheses, the study proposes the following research model (Figure 1).

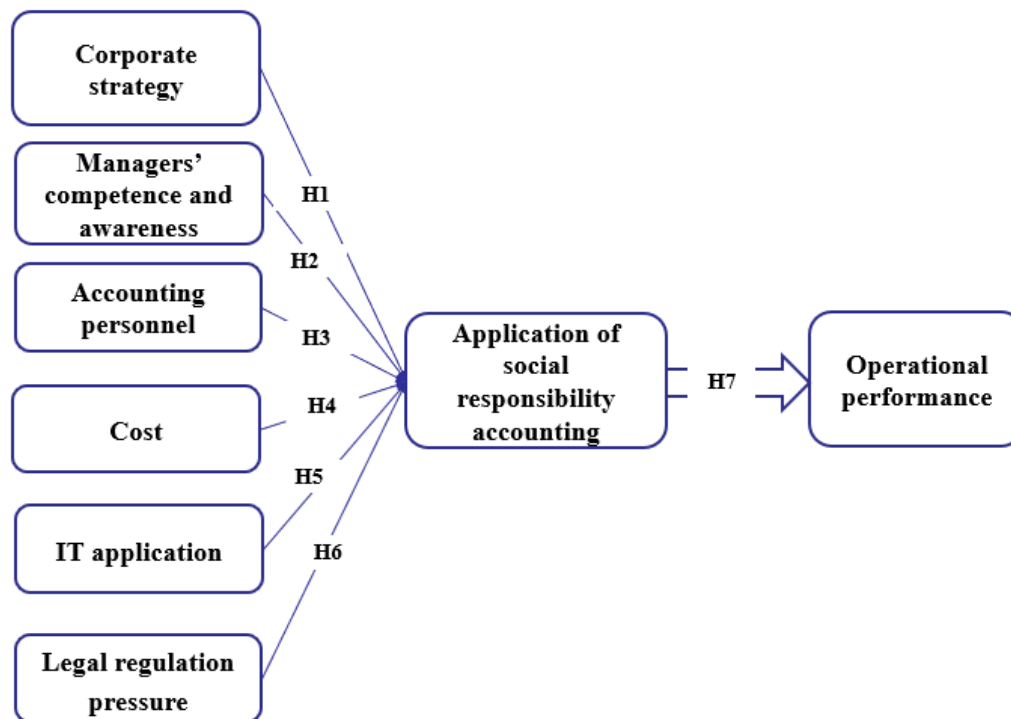

**Figure 1.** Suggested research model.  
Source: Prepared by the authors (2023).

## MATERIALS AND METHODS

### *Research Progress*

The research employed a combination of qualitative and quantitative approaches. Qualitative methods were utilized to explore the perspectives of experts and researchers regarding various factors influencing the effectiveness of internal audits. Specifically, the author conducted in-depth interviews with 10 accounting experts to identify variables representing these factors and operational performance. The observed variables measuring the research concepts were then refined and supplemented. Additionally, a preliminary survey was conducted with 20 interviewees who held managerial positions, such as CEOs, CFOs, and heads of accounting or





finance departments, to refine the questionnaire and scales. The formal study, on the other hand, employed a quantitative methodology. A survey was administered to 231 individuals, including CEOs, CFOs, managers, members of the board of directors, and heads of finance and accounting departments in Vietnamese enterprises. The purpose of this survey was to validate the measurement model, theoretical model, and hypotheses within the model. Several research techniques were utilized, including Pearson's correlation assessment, exploratory factor analysis, Cronbach's alpha reliability analysis, and regression analysis.

- Cronbach's alpha reliability analysis was employed to examine the correlation among the variables and evaluate Cronbach's Alpha coefficient. A scale with a Cronbach alpha value greater than or equal to 0.6 was considered acceptable, while variables with a total correlation coefficient (Corrected item-total correlation) below 0.3 were excluded, following the guidelines of Nunnally and Bernstein (2014).
- Exploratory factor analysis (EFA) was used as a quantitative analysis method to reduce a set of interrelated measurable variables into significant groups.
- Confirmatory factor analysis (CFA) was employed as a statistical technique to verify the factor structure of a set of observed variables. CFA allowed the researcher to test the hypothesis that a relationship exists between observed variables and their underlying latent constructs.
- Structural equation modeling, a multivariate statistical analysis technique, was used to analyze structural relationships. Similarly, combines factor analysis and multiple regression analysis to examine the structural relationships between measured variables and latent constructs.

### *\*Sampling*

In this study, the researcher employed a convenience sampling method to select a sample comprising 231 individuals, including CEOs, CFOs, managers, members of the board of directors, and heads of finance and accounting departments from enterprises in Vietnam. The survey was conducted by sending mail questionnaires directly to the internal auditors between September and December 2022. The sample size was determined to ensure the reliability of the results obtained from the exploratory factor analysis (EFA) and multivariate regression models. According to Hair *et al.* (1998), for EFA, the minimum sample size should be at least five times the total number of observed variables in the scales. In this study, the questionnaire consisted of 28 observed variables, thus requiring a minimum sample size of  $28 * 5 = 140$  observations. Hence, the author sent out 600 questionnaires to potential respondents. Ultimately, 231 valid responses were received and included in the analysis to assess the scale's reliability using Cronbach's alpha index, perform exploratory factor analysis, confirmatory factor analysis, and conduct structural equation modeling (SEM) to evaluate the impact of the application of social responsibility accounting on operational performance.

### *Empirical Results*

#### *Descriptive Statistics*

In terms of individual respondents, among the 231 collected votes, the majority consisted of CEOs and CFOs, totaling 61 votes. Following them, 19 individuals were heads of finance and



accounting departments, 11 were from the Board of Directors, and 6 were from other departments. Regarding the scope of the surveyed enterprises, out of the 231 collected votes, 23.76% represented large-scale enterprises, 44.55% were medium-sized enterprises, and 31.68% were small-scale enterprises.

### *Cronbach's Alpha Reliability Results*

**Table 1.** Cronbach's Alpha reliability test

Factor	Items	Cronbach's Alpha
Corporate strategy	Stra1, Stra2, Stra3, Stra4	0.891
Managers' competence and awareness	Mana1, Mana2, Mana3, Mana4	0.911
Accounting personnel	Acc1, Acc2, Acc3	0.889
The cost associated with implementing SRA	Cost1, Cost2	0.736
IT application	IT1, IT2, IT3, IT4	0.881
Legal regulation pressure	Legal1, Legal2, Legal3	0.866
Application of social responsibility accounting	SRA1, SRA2, SRA3, SRA4	0.917
Operational performance	Per1, Per2, Per3, Per4	0.904

Source: Results of SPSS data processing

The outcomes of Cronbach's Alpha testing revealed that Cronbach's Alpha coefficient for all factors surpasses 0.7, and the Corrected Item - Total Correlation of observed variables is from 0.3 or higher. This suggests that the observed variables within each scale exhibit similarity and there is a strong level of consistency across the scale (**Table 1**).

### *Exploratory Factor Analysis*

The Bartlett test was performed to examine the correlation among the observed variables, yielding a significance level (Sig.) of 0.000, which is below the threshold of 0.05. The KMO coefficients were found to be 0.852, which is higher than the threshold of 0.5 (**Table 2**). This indicates that there is no significant correlation between the observed variables in the population. As a result, the null hypothesis stating that the factor model is not suitable will be rejected, confirming that the data is highly suitable for factor analysis.

**Table 2.** KMO and Bartlett's Test

<b>Kaiser-Meyer-Olkin Measure of Sampling Adequacy.</b>		<b>.852</b>
	Approx. Chi-Square	5423.506
Bartlett's Test of Sphericity	df	378
	Sig.	.000

Source: Results of SPSS data processing

After exploratory analysis of EFA, the model has no difference compared with the research model, and no observed variable is excluded from the research variable. The observed variables are categorized into eight-factor groups, consistent with the original model. Furthermore, all the



observed variables exhibit factor loading coefficients greater than 0.5, demonstrating the appropriateness of the factor analysis. There is no new group of factors shown in **Table 3**.

**Table 3.** Pattern Matrix

	Factor							
	1	2	3	4	5	6	7	8
Per4	.956							
Per2	.955							
Per3	.953							
Per1	.942							
SRA1		.957						
SRA2		.925						
SRA3		.921						
SRA4		.843						
Mana3			.880					
Mana2			.861					
Mana1			.858					
Mana4			.776					
Stra1				.872				
Stra2				.834				
Stra4				.808				
Stra3				.754				
IT2					.868			
IT1					.868			
IT3					.775			
IT4					.713			
Legal3						.860		
Legal2						.815		
Legal1						.800		
Acc2							.921	
Acc1							.855	
Acc3							.702	
Cost1								.776
Cost2								.761

*Extraction Method: Principal Axis Factoring.*

*Rotation Method: Promax with Kaiser Normalization.*

*a. Rotation converged in 6 iterations.*

Source: Results of SPSS data processing

### *Confirmatory Factor Analysis Results*

The critical model consists of established factors that are interconnected without any imposed restrictions. The analysis conducted using Confirmatory Factor Analysis reveals favorable results. The Chi-square/df value is 1.964, the Comparative Fit Index (CFI) value is 0.940, the Tucker-Lewis Index (TLI) value is 0.929 (both exceeding the threshold of 0.9), the Goodness of Fit Index



(GFI) value is 0.845 (above the cutoff of 0.8), and the Root Mean Square Error of Approximation (RMSEA) value is 0.065 (below 0.8) (Figure 2). These values indicate that the model fits the data satisfactorily. Moreover, the factor weights assigned to each observed variable are greater than 0.5, confirming the model's convergent validity. Additionally, the model indices align well with the market data.

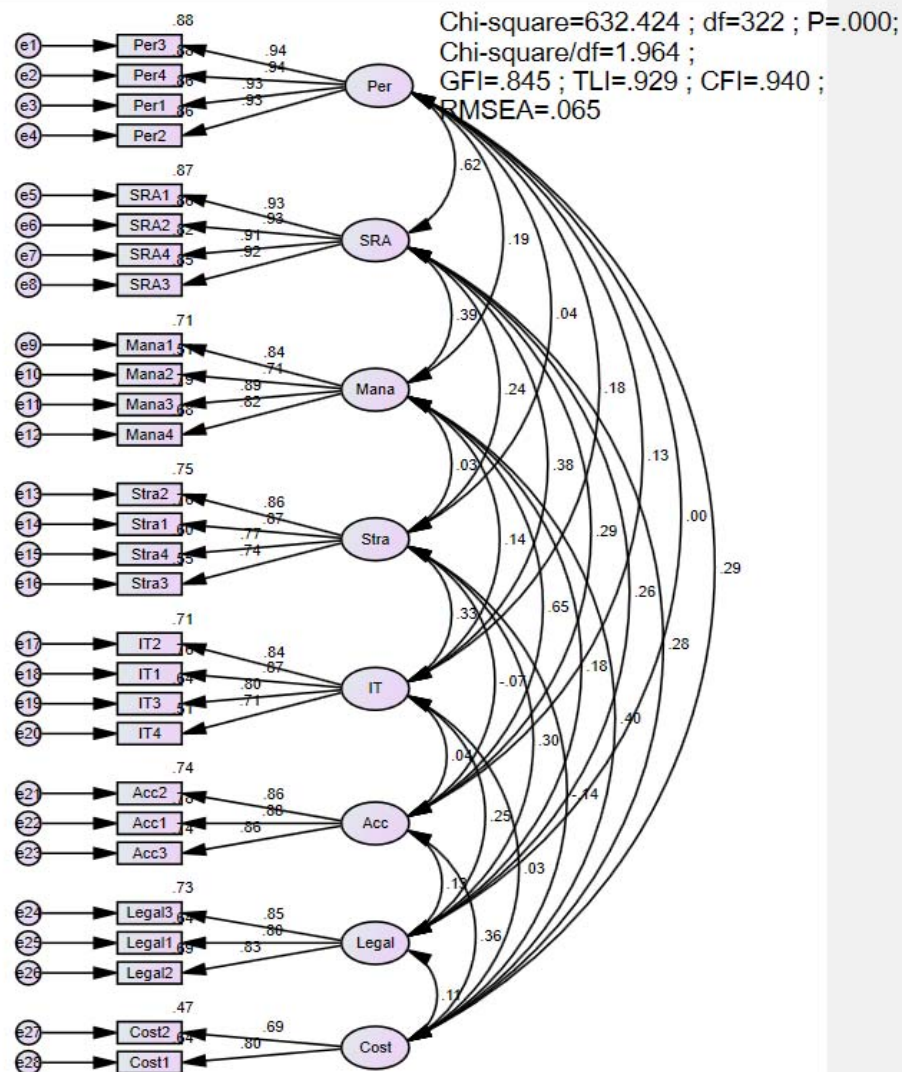
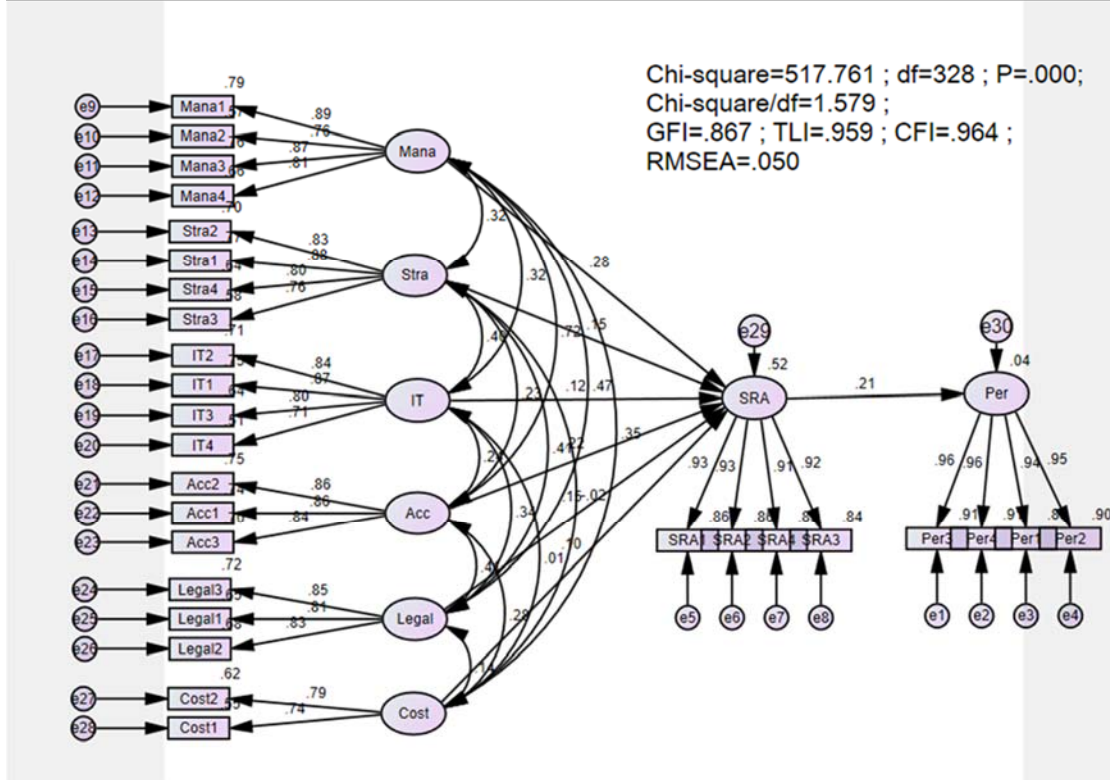

Figure 2. The Results of Confirmatory Factor Analysis  
Source: Results of SPSS data processing

*The Results of the Structural Equation Modeling (SEM)*





**Figure 3.** The results of the Structural Equation Modeling  
Source: Results of SPSS data processing

This study utilized the linear structural model SEM to assess the fitness of the research model and examine the relationships among the factors. The SEM analysis yielded the following results: degrees of freedom (df) = 328, Chi-square = 517.761,  $p = 0.000 < 0.05$ , Chi-square/df = 1.579 < 3, CFI = 0.964, TLI = 0.959, all greater than 0.9; GFI = 0.867 > 0.8, and RMSEA = 0.05 < 0.08 (Figure 3). These results confirm that the model is consistent with the market data. Table 4 displays the results of estimating the cause-and-effect relationships among the factors in the research model.

**Table 4.** The results of estimating the causal relationships among the factors

Correlations	Estimate	S.E.	C.R.	P	Hypothesis
SRA <--- Stra	.153	.063	2.438	.015	H1 accepted
SRA <--- Mana	.295	.097	3.055	.002	H2 accepted
SRA <--- Acc	.219	.083	2.646	.008	H3 accepted
SRA <--- Cost	.136	.084	1.608	.108	H4 rejected
SRA <--- IT	.123	.061	2.038	.042	H5 accepted
SRA <--- Legal	.156	.068	2.304	.021	H6 accepted
Per <--- SRA	.275	.087	3.164	.002	H7 accepted

(Source: Results of SPSS data processing)

The outcomes presented in **Table 4** indicate that hypotheses H1, H2, H3, H5, and H6 are supported, while hypothesis H4 is not supported. This implies that among the six factors examined regarding the implementation of social responsibility accounting, only five factors have a positive influence on its implementation. These factors include awareness and commitment of senior managers, accounting personnel, competitiveness level, IT applications, and legal regulation pressure. On the other hand, the cost associated with applying social responsibility accounting does not affect its implementation. Additionally, hypothesis H7 is confirmed, indicating a positive correlation between the performance factor of social responsibility accounting and business performance.

## RESULTS AND DISCUSSION

The research findings indicate that Hypotheses H1, H2, H3, H5, and H6 are accepted, suggesting that managers' competence and awareness, accounting personnel, corporate strategy, IT applications, and the legal regulation pressure all have a positive impact on the implementation of corporate social responsibility accounting in Vietnamese enterprises.

- The factor of awareness and commitment of senior managers exhibits the strongest influence on the implementation of social responsibility accounting ( $\beta = 0.295$ ). This finding is consistent with previous studies such as Colwell and Joshi (2013), Yang Spencer *et al.* (2013), and Hossain *et al.* (2015). It signifies that the awareness and commitment of senior managers, who are responsible for goal setting, policymaking, and decision-making, greatly influence the execution of social responsibility activities. Consequently, social responsibility accounting activities are also carried out to report on these activities.
- The factor of accounting personnel is the second most influential factor in social responsibility accounting implementation ( $\beta = 0.219$ ). This is entirely reasonable, as human resources play a decisive role in the effectiveness of activity execution within an organization. Specifically, to apply corporate social responsibility accounting, a well-trained accounting personnel team with appropriate knowledge, skills, and expertise is required. This finding further confirms and aligns with prior studies, including Zulkifli *et al.* (2009), Tran (2017), and Nguyen (2021).
- The third most influential factor in social responsibility accounting application is legal regulation pressure ( $\beta = 0.156$ ). The research findings align with Hossain *et al.* (2015) and Mukherjee *et al.* (2018). This outcome is consistent with the context in Vietnam, where the government has issued legal documents mandating listed enterprises to disclose information about their CSR activities. Consequently, social responsibility accounting needs to be implemented to collect, process, and provide CSR information and reports for publication. Moreover, our study's results support previous research.
- The corporate strategy has a positive influence on the extent of corporate social responsibility accounting application ( $\beta = 0.153$ ). This indicates that if an enterprise prioritizes the execution of social responsibility and the disclosure of CSR information in its strategies, it will stimulate the implementation of social responsibility accounting. This finding is consistent with previous studies such as Pavlatos (2015), Turner *et al.* (2017).



- The IT factor positively influences the application of corporate social responsibility accounting ( $\beta = 0.123$ ). The research findings are in line with previous studies. such as Choe (2004). Choe (2004) demonstrated a significant positive relationship between information technology and the amount of information generated through the management accounting information system.

## CONCLUSION

Additionally, a notable result of the study highlights a positive relationship between social responsibility accounting and the effectiveness of business operations ( $\beta = 0.275$ ). This finding is consistent with prior studies such as Tin and Hidayat (2012) and Tuan (2017).

Apart from the findings, the study does have certain limitations. Firstly, when examining the factors influencing the adoption of SRA, the research predominantly focuses on internal factors and does not delve into external factors, such as the competitive environment. Secondly, the study relies on a relatively small sample size of 231 managers from different levels. Expanding the survey sample in future studies may yield more intriguing outcomes.

**ACKNOWLEDGMENTS:** We would like to express our gratitude to the experts and interviewees who contributed their opinions and participated in the interviews for their great support during the data collection period. Without your help, we couldn't complete our research.

**CONFLICT OF INTEREST:** None

**FINANCIAL SUPPORT:** This research is funded by Hong Duc University, Thanh Hoa Province, Vietnam.

**ETHICS STATEMENT:** The present study adheres to the highest ethical standards in conducting research and respects the principles of integrity, transparency, and respect for all individuals involved. The research design, data collection, analysis, and reporting processes have been conducted with the utmost commitment to ethical guidelines and norms.

## References

- Al-Htaybat, K., & von Alberti-Alhtaybat, L. (2013). Management accounting theory revisited: Seeking to increase research relevance. *International Journal of Business and Management*, 8(18), 12.
- Al-Qudah, L. A. (2023). The role of social responsibility accounting in mitigating the economic impacts of the COVID-19 pandemic in Jordan. *Cogent Economics & Finance*, 11(1), 2171575.
- Choe, J. M. (2004). The relationships among management accounting information, organizational learning, and production performance. *The Journal of Strategic Information Systems*, 13(1), 61-85.
- Colwell, S. R., & Joshi, A. W. (2013). Corporate ecological responsiveness: Antecedent effects of institutional pressure and top management commitment and their impact on organizational performance. *Business Strategy and the Environment*, 22(2), 73-91.



- Galbreath, J., & Benjamin, K. (2010). An action-based approach for linking CSR with strategy: Framework and cases. In *Innovative Corporate Social Responsibility* (12-36). Greenleaf Publishing.
- Gray, R., Adams, C., & Owen, D. (2014). *Accountability, social responsibility and sustainability: accounting for society and the environment*. Pearson Higher.
- Gray, R., Owen, D., & Maunders, K. (1988). Corporate social reporting: emerging trends in accountability and the social contract. *Accounting, Auditing & Accountability Journal*, 1(1), 6-20.
- Hossain, M. M., Chowdhury, M. H., Evans, R., & Lema, A. C. (2015). The relationship between corporate social responsibility and corporate financial performance: Evidence from a developing country. *Corporate Ownership and Control*, 12(3), 474-487.
- Kalyar, M. N., Rafi, N., & Kalyar, A. N. (2013). Factors affecting corporate social responsibility: An empirical study. *Systems Research and Behavioral Science*, 4(30), 495-505.
- Khan, N., Abraham, O. O., Alex, A., Eluyela, D. F., & Odianonsen, I. F. (2022). Corporate governance, tax avoidance, and corporate social responsibility: Evidence of emerging market of Nigeria and frontier market of Pakistan. *Cogent Economics & Finance*, 10(1), 2080898.
- Ministry of Finance (2015), *Circular No. 155/2015/TT-BTC on guidance on information disclosure on the stock market*.
- Ministry of Finance (2020), *Circular No. 96/2020/TT-BTC on guidance on information disclosure on the stock market*.
- Mukherjee, A., Bird, R., & Duppati, G. (2018). Mandatory corporate social responsibility: The Indian experience. *Journal of Contemporary Accounting & Economics*, 14(3), 254-265.
- Nawaiseh, M. E., Zeidan, A. R., Falahat, M., & Qtish, A. (2014). An empirical assessment of measuring the extent of implementing responsibility accounting rudiments in Jordanian industrial companies listed at the Amman stock exchange. *Advances in Management and Applied Economics*, 4(3), 123.
- Nguyen, T. D. (2021). Factors affecting the ability to apply ABC accounting method: A case study of Vietnamese consumer goods enterprises. *Journal of Contemporary Issues in Business and Government Vol*, 27(1).
- Nunnally, J. C., & Bernstein, I. H. (2014). *Psychometric Theory*. New York. NY: McGraw-Hill.
- Pavlatos, O. (2015). An empirical investigation of strategic management accounting in hotels. *International Journal of Contemporary Hospitality Management*, 27(5), 756-767. doi:10.1108/IJCHM-12-2013-0582
- Raewf, M. B., & Jasim, Y. A. (2020). Information technology's impact on the accounting system. *Cihan University-Erbil Journal of Humanities and Social Sciences*, 4(1), 50-57.
- Su, R. J., & Jie, X. W. (2015). Literature review on corporate social responsibility. In *2015 International Conference on Management Engineering and Management Innovation (ICMEMI-15)*, 11-16. Atlantis Press.





- Su, S., Zhu, F., & Zhou, H. (2022). A systematic literature review on ownership and corporate social responsibility in family firms. *Sustainability*, 14(13), 7817.
- Susanto, A., & Meiryani, M. (2019). The impact of environmental accounting information system alignment on firm performance and environmental performance: A case of small and medium enterprises of Indonesia. *International Journal of Energy Economics and Policy*, 9(2), 229.
- Tran, M. P. (2017). *Factors affecting the implementation of social responsibility accounting in enterprises in Vietnam*. Master Thesis, University of Economics Ho Chi Minh City.
- Tran, V. T., Ly, P. C., Ngo, N. N. T., Tran, P. H., & Nguyen, V. C. (2022). Factor affecting the implementation of responsibility accounting on firm performance—Empirical analysis of listed textile firms. *Cogent Business & Management*, 9(1), 2032912.
- Tuan, T. T. (2017). Application responsibility accounting to sustainable development in Vietnam manufacturers: An empirical study. *Economics World*, 5(6), 573-583. doi:10.17265/2328-7144/2017.06.009
- Turner, M. J., Way, S. A., Hodari, D., & Witteman, W. (2017). Hotel property performance: The role of strategic management accounting. *International Journal of Hospitality Management*, 63, 33-43. doi:10.1016/j.ijhm.2017.02.001
- Van Marrewijk, M., & Werre, M. (2003). Multiple levels of corporate sustainability. *Journal of Business Ethics*, 44(2-3), 107-119.
- Voss, C. A., Åhlström, P., & Blackmon, K. (1997). Benchmarking and operational performance: some empirical results. *International Journal of Operations & Production Management*, 17(10), 1046-1058.
- Yang Spencer, S., Adams, C., & Yapa, P. W. (2013). The mediating effects of the adoption of an environmental information system on top management's commitment and environmental performance. *Sustainability Accounting, Management and Policy Journal*, 4(1), 75-102.
- Zulkifli, N., Telford, B., & Marriott, N. (2009). Social and environmental accounting in Malaysia: Practitioners' views. In *Accounting in Emerging Economies* (Vol. 9, pp. 145-167). Emerald Group Publishing Limited.

